

THE ALL-NEW MACK® MD SERIES

BUILT FOR GROWTH.



MACK MD7

Dependability, durability and steadfast support—everything you've come to expect from Mack is now available in a medium-duty truck. We're proud to introduce the Mack MD Series. These trucks, like the Mack MD7, are packed from the exterior to the driver environment with features to ensure a smooth, stress-free ride—and backed by our unmatched local dealer support. We've taken care of the details so you can focus on growing your business.

BORN READY.

MACK® MD7

KEY FEATURES

Cab air suspension (standard)	Tires 11R22.5 (standard)
Full-width aluminum grated steps, horizontally offset for visibility (standard)	Steel powder coat disc wheels (standard), aluminum wheels (optional)
50-gallon fuel tank (standard), 90-gallon (optional)	Passenger door lower peep window (standard)
Frame rails rated at 120,000 psi yield strength (standard)	Flat back-of-cab and clear body platform for easy body upfit
34-inch assembled frame width	Accommodates 10- to 26-foot typical van bodies
Rear leaf spring suspension (standard), Mack AirRide (optional)	Clear space on driver and passenger side frame rails



Comfortable Interiors

The Mack MD7 brings heavy-duty levels of driver comfort and functionality to medium-duty trucks, to keep drivers comfortable and safe all day. Tilt/telescoping steering column, air suspension driver seat and all controls within reach keep drivers in control.

All Day Uptime

Mack uses Geotab to integrate the MD7 into our industry-leading Uptime Services. Mack's ASIST platform streamlines and shares all service communications among the customer, dealer and Mack's 24/7 Uptime Center.

Typical Dry Van Body Length	(ft.)	10	12/14	16	18	20	22	24	26
Wheelbase*	WB (in.)	150	166	186	206	221	236	251	270
Cab to Rear Axle	CA (in.)	87	103	123	143	158	173	188	207
After Frame	AF (in.)	50	55	60	65	80	90	100	100
Overall Length Chassis	OL (in.)	240	261	286	311	341	366	391	410
GVWR	(lb.)	33,000	33,000	33,000	33,000	33,000	33,000	33,000	33,000
Front Axle Capacity	(lb.)	12,000	12,000	12,000	12,000	12,000	12,000	12,000	12,000
Rear Axle Capacity	(lb.)	21,000	21,000	21,000	21,000	21,000	21,000	21,000	21,000

*Wheelbase selection should be based on specific weight distribution.

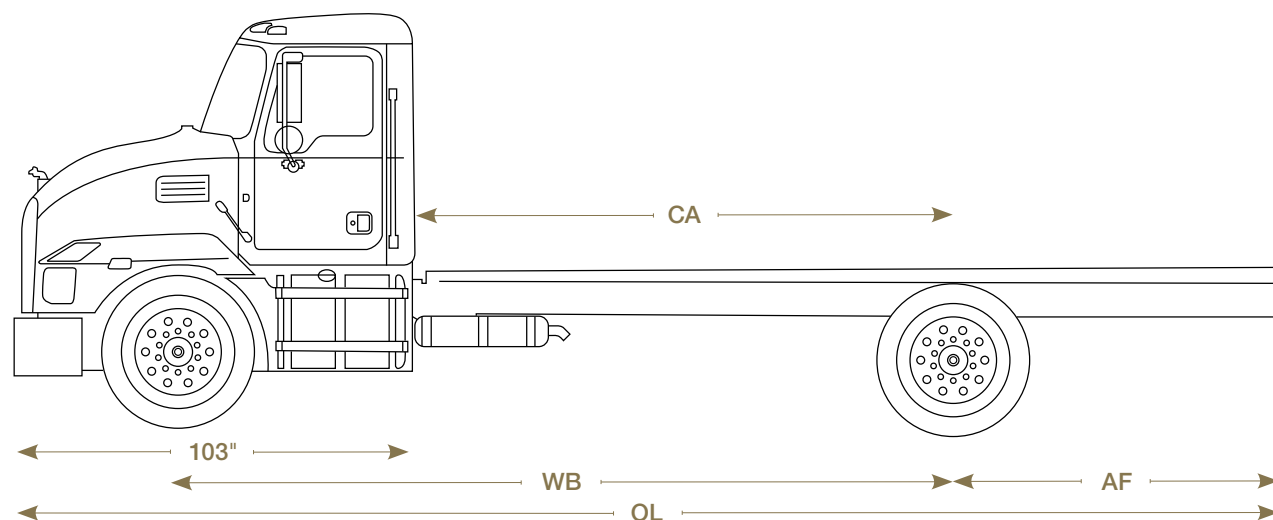

MACK® MD7

ENGINE	Cummins B6.7 Inline 6-cylinder, Turbo/Intercooled Diesel
Horsepower/Torque	220 hp/600 lb. ft.
	240 hp/560 lb. ft.
	250 hp/660 lb. ft.
	260 hp/660 lb. ft.
	280 hp/660 lb. ft.
300 hp/660 lb. ft.	
Air Cleaner Type	11 in.
Alternator	Delco 12V, 145 amp
Batteries	Dual 760CCA (1520 total CCA)
Engine Brake	Cummins, w/dash switch
Fuel Filter	Filter and Water Separator DAVCO Fuel Pro382 Heated
Starter	Melco12V

TRANSMISSION	STANDARD	OPTIONAL
	Allison 2500HS 6-speed, double OD rated to 660 lb. ft. torque, w/Fuel Sense 2.0 Plus	Allison 2500RDS 6-speed, double OD rated to 660 lb. ft. torque, w/Fuel Sense 2.0 Plus

RATIOS						
1st	3.51			3.51		
2nd	1.90			1.90		
3rd	1.44			1.44		
4th	1.00			1.00		
5th	0.74			0.74		
6th	0.64			0.64		
Rev.	-5.09			-5.09		
RA Ratio	5.29	5.57	5.83	5.29	5.57	5.83
Est Engine RPM @ 65 mph	1916	2018	2112	1916	2018	2112

FRONT AXLE

GAWR	12,000 lbs.
Axle Type	Meritor MFS-12, I-Beam
Suspension	Mack Taperleaf, 12,000 lbs.
Shock Absorbers	Telescopic type

REAR AXLE

	STANDARD	OPTIONAL	OPTIONAL	OPTIONAL
GAWR (lb.)	21,000	21,000	23,000***	23,000***
Axle Type – Meritor	MS-21-13x	MS-21-14x*	RS23-160	RS23-160 w/ DL*
Suspension – Taperleaf (lb.)	21,000	21,000		21,000
Suspension – Optional (lb.)	Mack AL210 21,000**			

Shaded areas indicate optional equipment.

CAB	Steel cab w/premium trim level
Air Conditioning	Standard
Audio	AM/FM w/Bluetooth
Cab Lighting	Interior courtesy lights – 2
Cab Mirrors	Bright finish & lower convex mirror
Cab Suspension	Dual, airbag cab suspension
Cruise Control	Standard
Cup Holders	Two large cup holders in console
Passenger Door Window	Lower door window w/ens
Power Outlets	12 volt & USB
Power Steering	Standard
Power Windows & Locks	Standard
Pro Dash	Premium dash cluster
Seat Driver	High back, air suspension w/vinyl
Seat Passenger	High back, fixed base w/vinyl
Steering Column	Tilt & Telescopic
Steering Wheel	Flat-bottom steering wheel
Sunvisors	Driver & Passenger

BRAKE SYSTEM

	Bendix Antilock Braking System "S" Cam Air Brake System
Front Brakes	Meritor S Cam, 16.5" x 5" Q+
Rear Brakes	Meritor S Cam, 16.5" x 7" Q+
Parking Brake	Rear axle, spring brake

FUEL TANK

	Round 22", driver-side. 50 gallons
	Round 22", driver-side. 90 gallons

DEF TANK

	Passenger side. 25L
--	---------------------

WHEELS

	Accuride steel disc, 5-hole powder coated white wheels 8.25 x 22.5, offset 6.6" Accuride
	Accuride aluminum, 10-hole wheels 8.25 x 22.5, offset 6.29"

TIRES

	Bridgestone R268 Ecopia radials All season, all position, 11R22.5 (G, 14PR)
	Bridgestone M729F Ecopia radials Traction, rear position, 11R22.5 (G, 14PR)

**14x & DL, Rear axle option equipped with driver controlled differential lock.

**Rear air suspension available on 206-, 221-, 236-, 251- and 270-inch wheelbases only.

***GAWR when equipped with 23,000 lb. rear axle is greater than 33,000 lbs. Vehicle will be subject to FET.

MACK® MD7



WARRANTY SUMMARY

MD Series Models MD6, MD7

Typical Vocations	Distribution, Short Haul or P&D
Axle Configuration	4 x 2
Basic Coverage	24 months/unlimited miles*
Batteries	12 months/unlimited miles
Chassis Towing	90 days or 5,000 miles (8 047 KM), whichever occurs first*
Air Conditioning	24 months/unlimited miles – air conditioning (sealed system only)
Engine/Emission	Warranty provided by Cummins.
Transmission	Warranty provided by Allison.
Driveline, Rear Axle, Front Steer Axle	24 months/unlimited miles*
Cab Structure & Internal Cab Corrosion	60 months/unlimited miles*
Frame Rail/Crossmembers	60 months/unlimited miles*
Noise Emission	Life of vehicle*

*See complete warranty certificate for details.

Shaded areas indicate optional equipment.

All illustrations, specifications and descriptions in this specification are based on the latest product information available at the time of this publication. The right is reserved to make changes in price, materials, equipment, design, specifications, diagrams and models, and to discontinue models of equipment at any time, without notice and without incurring any obligation whatsoever. For more information on additional options and accessories, contact Mack Trucks, Inc. (www.macktrucks.com).

UPTIME SUMMARY

MD Series Models MD6, MD7

Mack OneCall	12 months
Mack ASIST	12 months
Geotab Basic	12 months
PURCHASE OPTIONS	
Mack OneCall	24-60 months, in 12 mo. increments
Mack ASIST	24-60 months, in 12 mo. increments
Geotab Basic	24-60 months, in 12 mo. increments
Geotab Plus	12-60 months, in 12 mo. increments

OTHER OPTIONS

Allison Upgrade	Fuel Sense 2.0 MAX
Battery Shut Off	Under cab, passenger side
Engine Block Heater	
Air Filter Indicator	Under hood, restriction indicator mounted to air cleaner
PTO Preparation Kit	Harness & switch kit
Cab Mirrors	Chrome finish & convex mirror heated & motorized
Seat Passenger	Two-person bench seat w/vinyl & under seat storage
Drivers Seat Trim	Modura cloth upgrade seat upholstery
Passenger Seat Trim	Modura cloth upgrade seat upholstery
Passenger Bench Trim	Modura cloth upgrade seat upholstery